



ETC-F050

Focus Adjustment Controller User Manual

Empower

Hotline: +86 400-6760-1510

Email: sales@empower.cn

Add: 1500xinfei Road No.72, Shanghai, China



Version:	V2.0
Date:	2018/01/05

Historical Version:

Historical Version	Date of Release	Brief description of alteration	Editor	Date of Edit	Reviewer	Date of Review
V1.0		Initial Edition	Emmy	2018/01/05		2018/02/26
V2.0		Add the offset correction function	Bruce_liu	2018/8/01		

Contents

1	Product Introduction	3
1.1	Intro	3
1.2	Parameter.....	4
1.3	Dimension	5
1.4	Interface Specification.....	6
2	Operating Instructions	7
2.1	Button	7
2.2	System hierarchy graph	8
2.3	Main interface.....	9
2.4	HOME OPS	10
2.5	PARA SET	10
2.6	FUNC TEST	11
2.7	ADV SET	12
3	Application example	14
3.1	ETC-F050+BM 109	14
3.1.1	Wiring diagram	14
3.1.2	Wiring Note.....	15
3.1.3	Debug.....	16
3.1.4	Focus control relation	17
4	Alarm Information Analysis	18
4.1	Driver Alarm.....	18
4.2	OverTravel.....	18
4.3	Limit Alarm	18
4.4	Home First.....	18

1 Product Introduction

1.1 Intro



The ETC-F050 is a focus adjustment controller designed for the focus adjustment of the auto-focusing laser head. The ETC-F050 performs closed-loop control based on the feedback position information of the encoder, which can accurately control the focus quickly to the target position with an accuracy of $\pm 0.01\text{mm}$.

ETC-F050 has the following features:

1. The focus position can be controlled by an external voltage signal (0~10V);
2. The focus offset correction function corrects the focus shift due to mechanical errors;
3. Focus adjustment is fast and accurate, $\pm 0.01\text{mm}$ error can meet the needs of most users;
4. Control the focus movement through the numerical control system and output the in-position signal.
5. The human machine interface is convenient for users to install and debug, and the firmware can be upgraded through the serial port.

1.2 Parameter

Items of Para.	ETCF050
Input channel	4x Digital, 1x Analog
Output channel	2x Digital
Rated voltage	24VDC \pm 10%
Focus speed	100mm/s (3000r/min, 2mm lead)
Focus accuracy	\pm 0.01mm
Rated current	85mA
Working temperature	-20 $^{\circ}$ C \sim +60 $^{\circ}$ C
Storage temperature	-40 $^{\circ}$ C \sim +80 $^{\circ}$ C
Relative humidity	10~80%
Protection class	IP20
Machine size	175mm*54mm*90mm
Weight	500g
Order NO.	ETC F050 0100

1.3 Dimension

The overall dimensions of the ETC-F050 main controller are shown below (unit: mm):

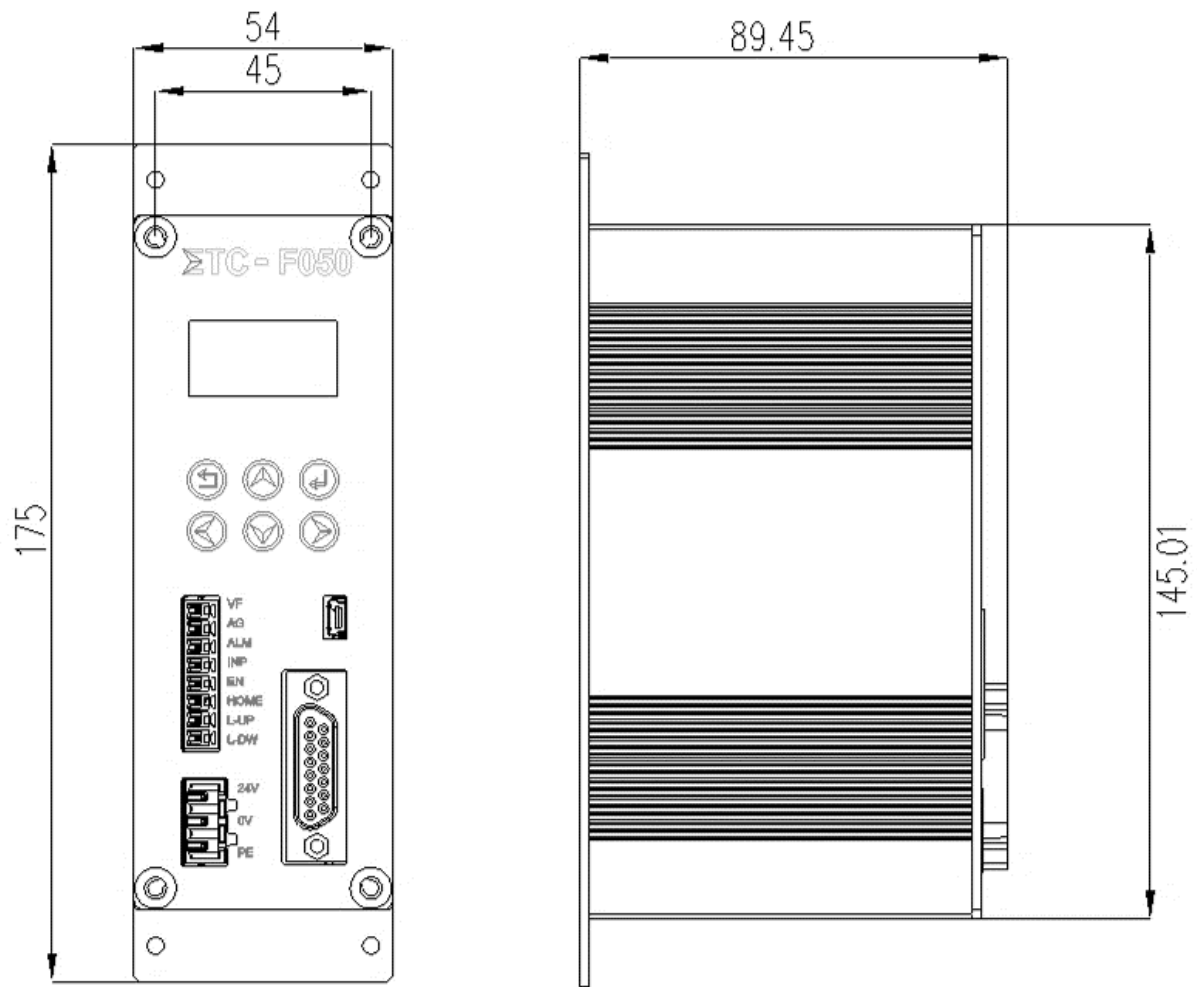

1.4 Interface Specification

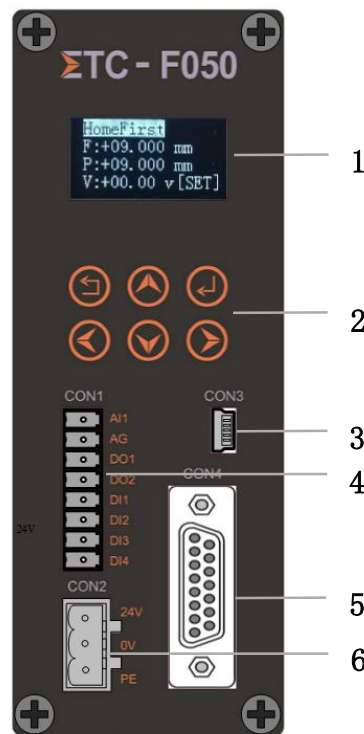

HMI







No.	Interface	Specification
1	Display screen	Display ETC-F050 operation information and user operation interface
2	Buttons	Operate the ETC-F050
3	CON3	USB interface for firmware upgrade
4	CON1	I/O Port
5	CON4	DB15 female connector, connect to motor driver.
6	CON2	24V DC power supply interface

Pins of CON1:

Pin	Definition	Specification
AI1/VF	FocusSet	The input signal of focus setting (0~10V)
AG	AGND	Analog signal ground.
DO1/ALM	ALMOUT	Output 24V when alarm occurs.
DO2/INP	FocusINP	Output 24V when focus in position.
DI1/EN	FocusEN	High-level control focus on, low-level control focus off.
DI2/HOME	HOME	Input signal of homing, high active.
DI3/L-UP	Uplimit	Input signal of up limit, low active.
DI4/L-DW	Downlimit	Input signal of down limit, low active.

2 Operating Instructions

2.1 Button

Button		Function
	ESC	Exit and return to previous menu.
	ENT/SAVE	Go to the submenu or enter the setup menu; Save the parameter.
 	Left/right	① In the main interface: Left key: focus enable on; Right key: focus enable off. ② In the parameter setting interface: Left and right keys for parameter setting.
 	Up/down	① In the main interface: Up key: Jog up; Down key: Jog down (turn off focus enable in advance) ② In the parameter setting interface: Control the cursor up and down, and make menu selection

2.2 System hierarchy graph

The system function hierarchy graph show as below:

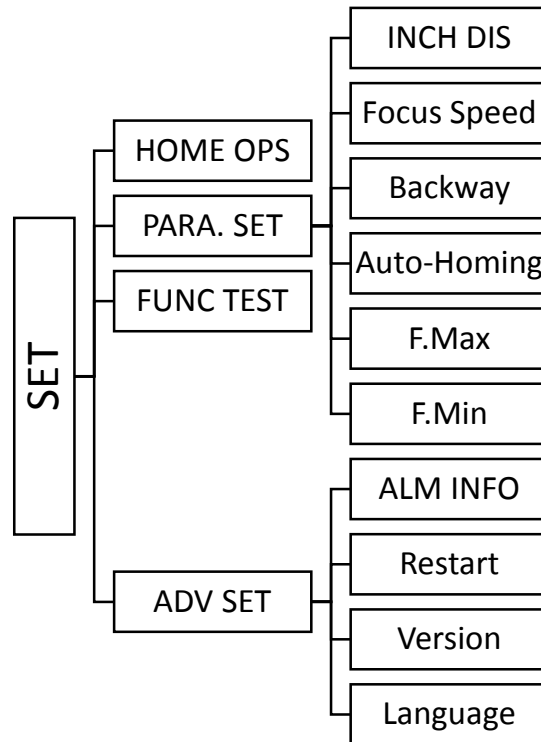

2.3 Main interface

After the system is powered on and initialized, it automatically enters the main interface. As shown below:

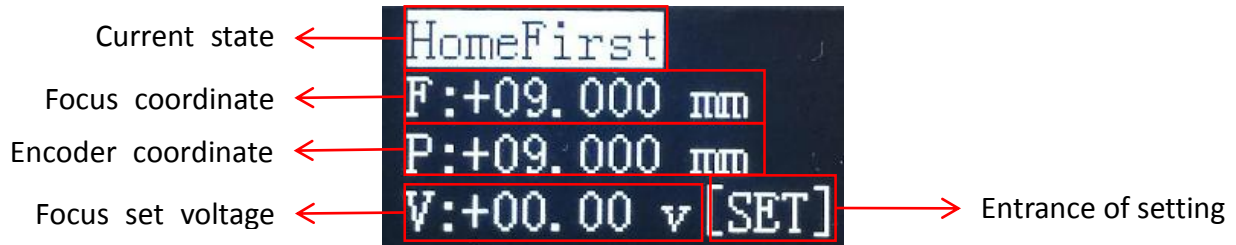

What displayed on the main interface include:

Current state	Description
Stop	The F-axis focus is in motionless state.
Focusing	The F-axis focus is in a dynamic adjustment state.
MoveUp	In the jog mode, the focus is in an upward motion state.
MoveDown	In the jog mode, the focus is in a downward motion state.
Alarm information	Please refer to chapter 4.

Focus coordinate F:

The focus position obtained from the input analog voltage changes as the input voltage changes.

Encoder coordinate P:

The current actual position (encoder value) of the motor, The P value is consistent with the laser head pointer coordinate after the 0 focus correction.

Analog input (V):

This value is the input analog voltage of the focus position.

2.4 HOME OPS

Home is the process of finding the up limit position by the upward movement of the dial then determining the position of the 0 focus. In the following interface, select Home and then press “ENT” to start homing.

```

HOME OPS <=
PARA SET
FUNC TEST
ADV SET   [ENT]
    
```

Note: The home can be completed by manual home operation, or it can be completed by external input home signal or by turning on the auto-homing function.



Attention !

Before homing, please confirm that the limit signal is valid. The focus dial is between the two limits. Otherwise, it may cause mechanical failure.

2.5 PARA SET

Sub-menu of PARA SET:

```

INCH DIS <=
1000 um
Focus Speed
50 mm/s [ENT]
    
```

```

Backway <=
08.50mm
Auto Homing
Y N [ENT]
    
```

```

F. MAX <=
+09.00mm
F. MIN
-09.00mm [ENT]
    
```

INCH DIS:

The jog motion mode of the ETCF050 is inching, that is, the setting inch distance that the focus move each time when the up/down button is triggered.

Focus Speed:

When focusing enabled, the maximum speed at which the focus moves to the target position.

Backway:

The distance that the dial move downward after triggering up limit during the homing process. It is used to correct the offset of zero focus. Set the Backway appropriately to ensure that the laser head pointer is aligned with the 0 scale after homing is completed.

Auto-homing:

After turned on, the ETCF050 will automatically do home operation after the system power-on and initialization is completed. Please turn on the Auto-homing after debugging is completed.

F.Max:

The maximum adjustable range of positive focus.

F.Min:

The maximum adjustable range of negative focus.

2.6 FUNC TEST

Function test interface:

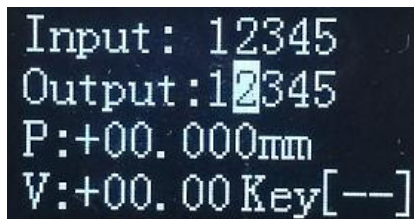

```

Input: 12345
Output: 12345
P:+00.000mm
V:+00.00 Key[--]
    
```

It includes input and output signals, encoder coordinate P, input voltage V and Key/Button. In the input and output ports, when the signal is valid, the corresponding data bit will be reversed, and the validity of the port signal needs to be tested during diagnosis. The Key/Button displays the validity of

the button when pressing it. Move the dial up and down to see if the encoder coordinate P changes.

IO signals:

Signal Type	1	2	3	4	5
Input	ServoALM	Uplimit	Downlimit	FocusEN	HOME
Output	ALMOUT	FocusINP	ServoEN	ServoDir	State

Output 5: Program running status, flash every 2 seconds.

2.7 ADV SET

Sub-menu of ADV SET:

```

ALM INFO <=
Restart
Version
Language [ENT]
    
```

1. ALM INFO: This interface saves the historical alarm information. The smaller the serial number, the newer the status.

```

1. DWLimitALM
2. UPLimitALM
3. HomeFirst
ESC          Clear
    
```

2. Restart: This operation is equivalent to turning off and powering on the ETC-F050.

Restore factory settings: Restore factory settings.

Note: After restoring factory settings, reconfigure the relevant parameters and perform cutting and processing without problems after testing

```

Restart <=
Y  N
Reset
Y  N [ENT]
    
```

3. Version: Display the software and hardware versions of ETC-F050.

```

Software Version
V2.2.8647
Hardware Version
V1.5.0000 [ESC]
    
```

4. Language: Support Chinese and English user interface.

```

中文 <=
English
[ENT]
    
```

3 Application example

3.1 ETC-F050+BM 109

3.1.1 Wiring diagram

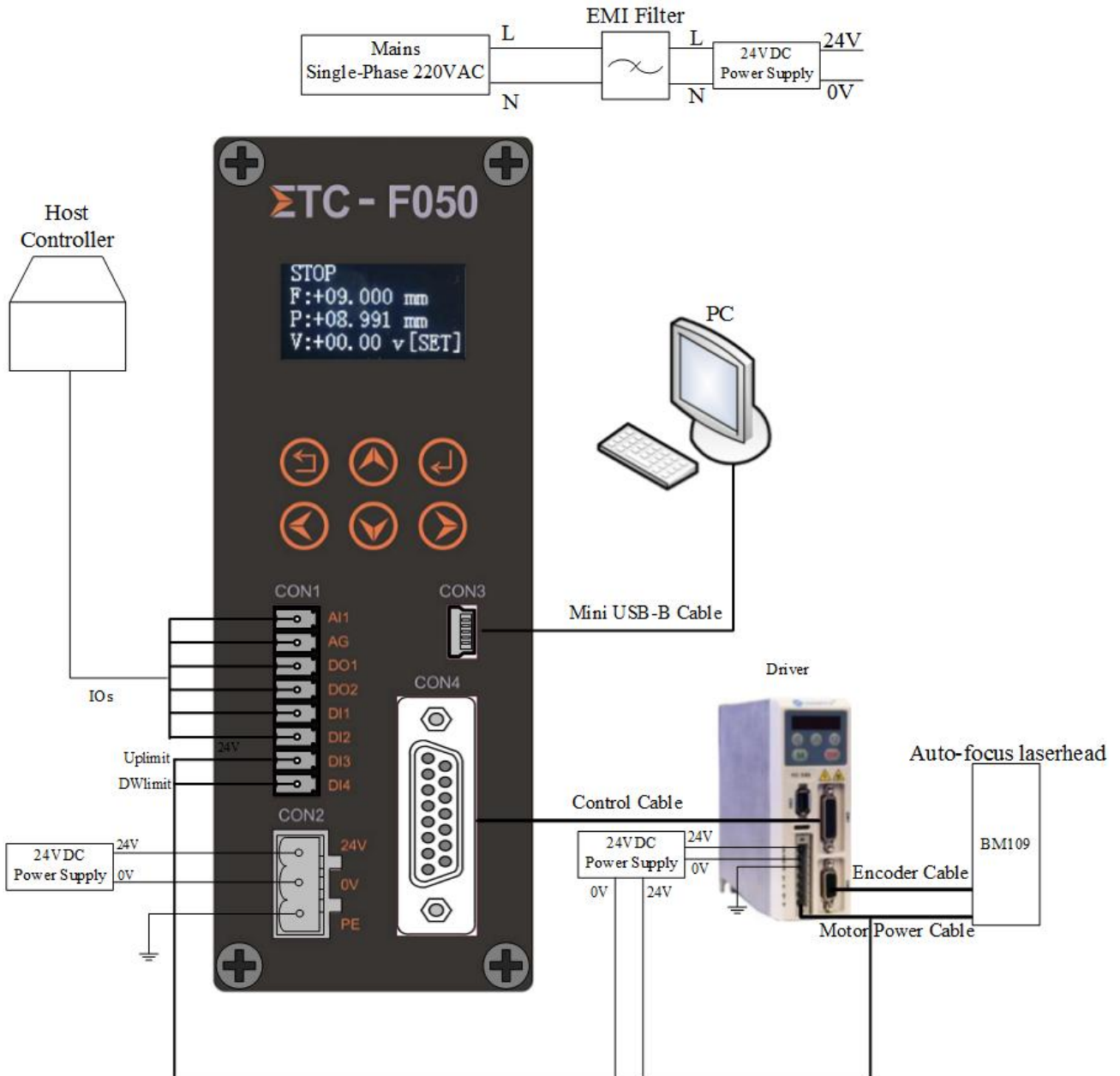

Note: Mini USB-B is only used for firmware upgrade, 24VDC power supplies is the same power supply.

3.1.2 Wiring Note

1. Ground

The driver control cable has its own shield and is electrically connected to the metal shield on both sides. The driver control cable is connected to the drive controller at one end and the ETC-F050 control box at the other end. The grounding requirements are as follows:

- 1) Ensure that the ground of the driver is well grounded;
- 2) Ensure that the PE of the ETC-F050 is well grounded.

2. Power supply

- 1) 24VDC is used to supply power to the driver、ETC-F050 controller、and limit sensors. The same power supply is required. If different power sources are used, please ensure that the 0Vs are connected. Also make sure that the power supply is sufficient.
- 2) If the 24V power supply is too disturbed and affects the normal operation of the controller, the focusing system should be powered separately or an additional EMI filter can be added.

3. IO

In order to obtain the basic focusing function of ETC-F050, it is necessary to connect the up and down limit signals (DI3/L-UP, DI4/L-DW), focus enable (DI1/EN), focus set (AI1/VF), and analog ground (AG), focus in-position signal (DO2/INP), other signals can be accessed according to demands. Do not connect to the 24VDC power supply in the control module of the IO that needs to be connected to the system.

3.1.3 Debug

1) Confirm the driver status

After the system is powered on, if the drive does not display “Er020” and the given data pulse is decremented to 0, the drive status is normal.

2) Confirm the up and down jog operation of ETC-F050

Press the up and down keys, the dial in focus window of the laser head moves up and down.

3) Zero focus positioning

Do home operation. Observe whether the pointer is aligned with 0 after home completed. If the 0 focus is offset, please correct the ETC-F050's backway parameter until the 0 focus is aligned after the home is completed. The F.Max and F.Min remain at the default value of ± 9 mm.

(Backway modification: If the pointer scale is negative after home is completed, the backway is appropriately reduced; if the pointer scale is positive after home, the backway is appropriately increased)

4) Focus control

↓ The host computer outputs the HOME signal (DI2/HOME), observe whether the dial operates accordingly, and confirm the following operations.

↓ The host computer outputs FocusSet analog 5V (VF/AI1), the output FocusEN signal (DI1/EN), observes whether the pointer is aligned with the 0 scale position, and the ETCF050 panel displays the V value as 5V, the P coordinate is 0; change the analog quantity Size, observe whether the focus moves to the corresponding position. At this time, the host computer can detect the FocusINP signal (24V).

3.1.4 Focus control relation

ETC-F050 working with BM109 auto-focusing head and after focus offset calibration, 0V corresponds to the maximum positive focus (F.Max), and 10V corresponds to the maximum negative focus (F.Min), which is linearly corresponding relation. Taking the focus range $\pm 9\text{mm}$ as an example, the correspondence between the focus and the input analog quantity is as follows:

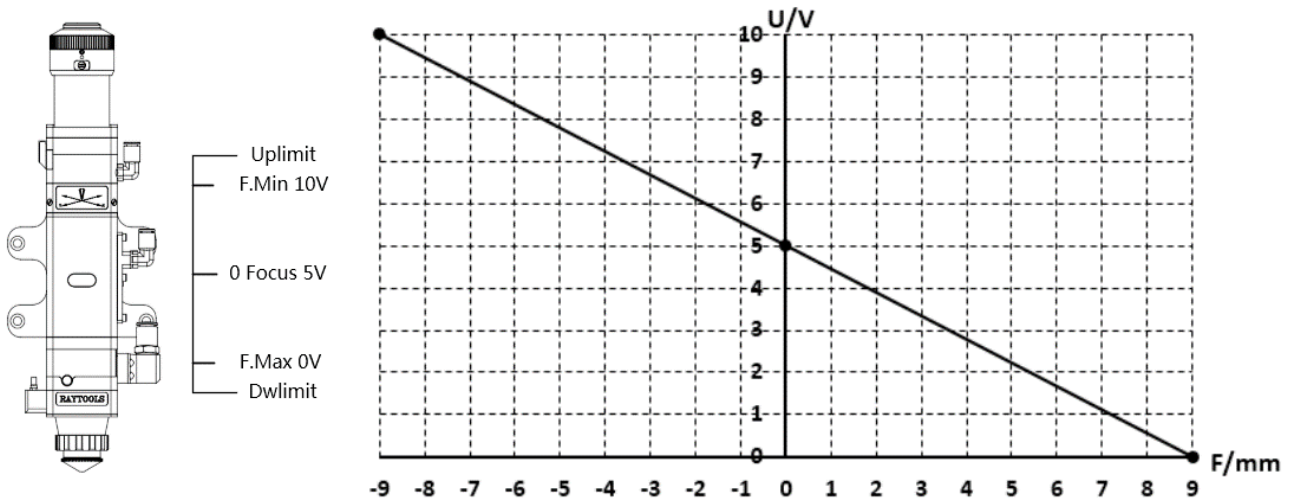

Focus-Voltage relation (F-V):

$$V = \frac{-10 \times (F - F.Max)}{(F.Max - F.Min)}$$

(EX: Calculate the voltage corresponding to +5 focus (F) : $V = \frac{-10 \times (5-9)}{9-(-9)} = 2.22 \text{ v}$, F.Max > F > F.Min)

Note:

1. The above formula focus unit is millimeter (mm), the voltage unit is volt (v);
2. If the F.Max and F.Min are asymmetrical, the focus correspondence is different from the figure above. At this time, the 5V analog quantity does not correspond to the 0 focus position.

4 Alarm Information Analysis

4.1 Driver Alarm

When the driver alarms, an alarm is displayed. The possible reasons are as follows:

- 1) The driver wiring is incorrect;
- 2) External disturbances.

4.2 OverTravel

This alarm is generated when the actual focus coordinate (P) is greater than the range restricted by the F.MAX and F.MIN. Please note when this alarm occurs:

- 1) Is the F.MAX or F.MIN setting correct;
- 2) Is the position of the dial over travel.

4.3 Limit Alarm

This alarm is generated when the system detects a sensor trigger signal of the up or down limit of the F-axis. If this alarm is displayed all the time, please check:

- 1) The limit signal cable is not connected to ETC-F050;
- 2) The limit signal is disturbed. At this time, the corresponding limit signal may flicker in the function test, especially after being enabled on the machine tool, and it is suggested to independently power ETC-F050 with the 24VDC of the limit signal at this time.

4.4 Home First

After the system restarts, the controller needs to re-establish the reference coordinate system. If do not finish homing, the screen displays "HomeFirst". This can be solved by the following methods:

- 1) Do home operation through the buttons on the panel;
- 2) Select "Y" and save in the Auto Homing option;
- 3) Controlled by the home signal.